



Outperform every day.™

Project:

Item Number:

Quantity:

MIRAGE® DROP-IN INDUCTION WARMERS AND RETHERMALIZERS



DESCRIPTION

Mirage® Drop-in Induction Warmers and Rethermalizers use innovative induction technology to run dry (without a water bath), improve food quality and minimize food waste; while using a fraction of the energy. They are shipped complete with an induction-ready inset and slotted hinged cover. The cover is not NSF.

WARMER PERFORMANCE CRITERIA

Mirage® Drop-in Induction Warmers are designed to hold heated prepared foods at temperatures above the HACCP “danger zone” of 140° F (60° C). The performance standard is measured using the NSF mixture preheated to 165° F (73.9° C). The unit will hold the temperature of this product above 150° F (65.6° C). The temperature will be maintained best when the food product is held using pans with covers, and the food product is stirred regularly.

RETHERMALIZER PERFORMANCE CRITERIA

The Mirage® Drop-in Induction Rethermalizers are designed to take a container of cooked food from a chilled state (below 40.0° F [4.4° C]) through the HACCP “danger zone” of 165° F (73.9° C) in less than 90 minutes. The performance standard is measured using the NSF mixture chilled to 35° F (1.7° C). The electric unit will raise the temperature of this product above 165° F (73.9° C) in less than 90 minutes. The temperature will be maintained above 150° F (65.6° C) when the food product and pan or inset are used with a standard pan or inset cover, and the food product is stirred regularly.

Agency Listings



This device complies with Part 18 FCC Rules.

Cover is not NSF.

Due to continued product improvement, please consult www.vollrath.com for current product specifications.

ITEMS

- 74701DW Induction Warmer, 7Qt. (US/CAN)
- 74701D Induction Rethermalizer, 7 Qt. (US/CAN)
- 741101DW Induction Warmer, 11 Qt. (US/CAN)
- 741101D Induction Rethermalizer, 11 Qt. (US/CAN)

FEATURES

- 3D induction coil heats food evenly and efficiently. Dry use. Heat is transferred directly to the induction-ready inset, which eliminates the need to monitor and refill water levels.
- Three temperature sensors have direct contact with the inset to provide very accurate temperature control. Sensors help prevent food in near-empty insets from burning, which maintains food quality and reduces food waste.
- Sensors measure differences in food temperatures. This drives the Stir Indicator LED that informs operators the food product should be stirred.
- Advanced solid state controls with highly visible white LEDs include: temperature control in °F and °C; four presets - broth soups, crème soups, chili, mac and cheese; rethermalize mode (800W units only); stirring indicator; and a locking function that prevents untrained operators from changing settings.
- Includes cover — item 47488 for 7 Qt. or 47490 for 11 Qt., and inset — item 88184 for 7 Qt. or item 88204 for 11 Qt. Covers and insets are also sold separately.
- Requires use of included Vollrath induction-ready inset.
- Meets NSF4 Performance Requirements for rethermalization and hot food holding equipment.
- Bottom exit 6' (1.8 m) power cord.
- Bottom exit 58" (1.5 m) control cord.
- Includes mounting hardware.

WARRANTY

All models shown come with Vollrath’s standard warranty against defects in materials and workmanship. For full warranty details, please refer to www.vollrath.com.

ACCESSORIES

- 47491 decorative stainless steel ring for 7 Qt. induction drop-in
- 47492 decorative stainless steel ring for 11 Qt. induction drop-in

CLEARANCE AND ENVIRONMENT REQUIREMENTS

- All models require unrestricted intake and exhaust air ventilation for proper operation of the controls. The maximum intake temperature must not exceed 110°F (43°C). Temperatures are measured in ambient air while all appliances in the kitchen are in operation.
- Zero clearance between the sides of the drop-in and any surrounding surface.

Approvals	Date



Outperform every day.™

www.vollrath.com

The Vollrath Company, L.L.C.

1236 North 18th Street
Sheboygan, WI 53081-3201 U.S.A.
Main Tel: 800.624.2051 or 920.457.4851
Main Fax: 800.752.5620 or 920.459.6573
Customer Service: 800.628.0830
Canada Customer Service: 800.695.8560

Technical Services
techservicereps@vollrathco.com
Induction Products: 800.825.6036
Countertop Warming Products: 800.354.1970
All Other Products: 800.628.0832

MIRAGE® DROP-IN INDUCTION WARMERS AND RETHERMALIZERS

DIMENSIONS (shown in inches (cm))

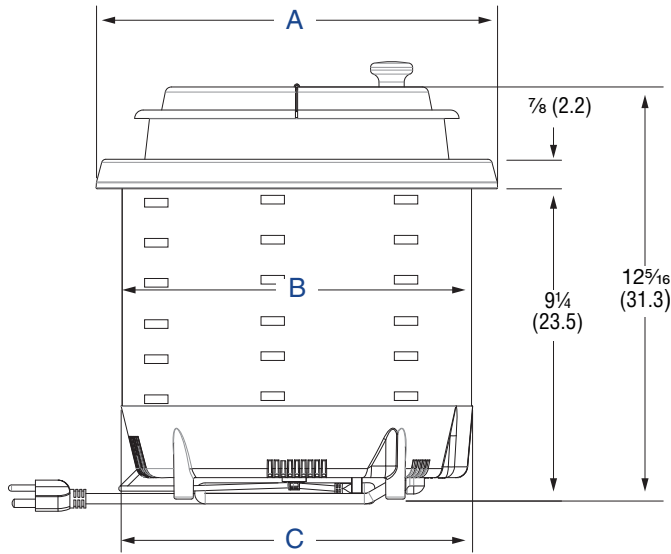

Front/Side View

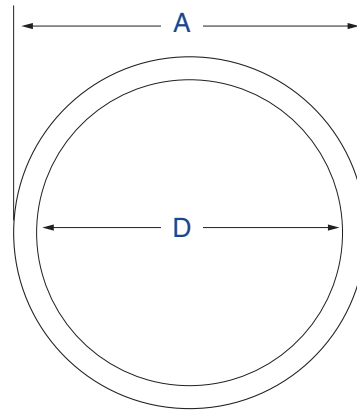

Top View

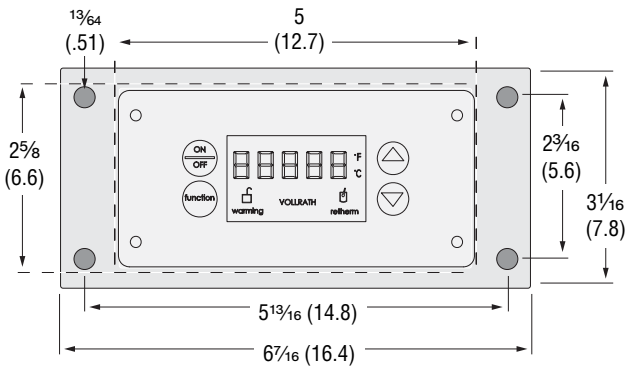

Control Box Front

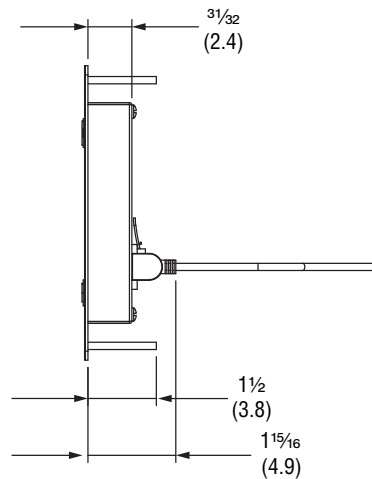

Control Box Side

SPECIFICATIONS

Item No.	Capacity QT (L)	Description	Dimensions					Voltage	Watts	Amps	Plug
			(A) Overall Width	(B) Drop-in Body Width	(C) Drop-in Max Width	Well Depth	(D) Cutout Diameter				
74701DW	7 (6.6)	Warmer	11 7/8 (30.3)	10 3/8 (26.4)	10 7/16 (26.5)	6 7/8 (17.6)	10 3/8 (27)	120	250W	2.1	NEMA 5-15P
74701D		Rethermalizer							800W	6.7	
741101DW	11 (10.4)	Warmer	13 7/8 (35.3)	12 3/8 (31.4)	12 7/16 (31.2)	6 7/8 (17.6)	12 5/8 (32.1)	120	250W	2.1	NEMA 5-15P
741101D		Rethermalizer							800W	6.7	

Receptacle

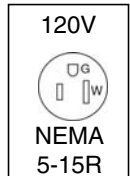

Outperform every day.™

www.vollrath.com

The Vollrath Company, L.L.C.

1236 North 18th Street
Sheboygan, WI 53081-3201 U.S.A.
Main Tel: 800.624.2051 or 920.457.4851
Main Fax: 800.752.5620 or 920.459.6573
Customer Service: 800.628.0830
Canada Customer Service: 800.695.8560

Technical Services
techservicereps@vollrathco.com
Induction Products: 800.825.6036
Countertop Warming Products: 800.354.1970
All Other Products: 800.628.0832